



## Module 2

# OPERATION AND MAINTENANCE OF WATER SUPPLY SYSTEM

Training Module for Local Water and Sanitation Management

Maharashtra Jeevan Pradhikaran (MJP)  
CEPT University

2012

## CONTENT

	Introduction	3
Module A	Basics about Operation and Maintenance of Water Supply System	4
Module B	Operation and Maintenance of Local Ground Water Source and Water Quality Monitoring	8
Module C	Operation and Maintenance of Pumping Machinery	19
Module D	Operation and Maintenance of Water Treatment Units	26
Module E	Operation and Maintenance of Water Distribution System and Storage	39
	References	36

## ABBREVIATIONS

CPHEEO	Central Public Health and Environmental Engineering Organisation
HH	House Hold
mg	Milli Gram
MJP	Maharashtra Jeevan Pradhikaran
O & M	Operation and Maintenance
PHED	Public Health Engineering Department
PVC	Ploy Vinyl Chloride

## INTRODUCTION

Water Supply in India is now previewed as community based demand driven system, under which it is essential to enhance capacity of local community residing in villages and small towns to develop and manage their own water supply systems.

Role of community groups is to ensure effective and participatory implementation of water supply system in their village/town, water quality control, financial management and effective operation and maintenance of water supply system established.

Hence, it is evitable that such community groups are aware about the basics of water supply system, operation and maintenance of water assets and water supply system as well as basics of sanitation and waste management.

This training course series has been formulated in order to enhance capacity of community groups for enhanced operation and maintenance of water supply and sanitation systems in their village/town.

Module on “Operation and Maintenance of Water Supply System” provides insights on methods for O&M of water supply system for its effective functioning.

## MODULE A: BASICS ABOUT OPERATION AND MAINTENANCE OF WATER SUPPLY SYSTEM

### Training Objectives

To understand the objectives and basic consideration for O&M of water supply system.

**Training tools:** Slideshow, powerpoint /on board presentation, question answer

**Approximate time:**

Presentation: 15 minutes

Slideshow, question answer: 15 minutes

TOTAL 30 minutes

## A1 What does Operation and Maintenance of Water Supply System Indicate

- The Major objective of operation and maintenance of water supply system is to provide sustainable, equitable, consistent, economic safe and adequate water.
- Operation of system in general means ensuring effective routine running of system timely and daily.
- Maintenance in general means up keep of structures/system including planned, preventive or corrective maintenance, repairs etc.

## A2 Basic considerations for O&M of Water Supply System

1. Preparation of water supply network map of village/town starting including water source, head works, treatment and distribution network.
2. Preparation of O&M Plan
  - Preparation of a plan involves list of routine tasks, specific tasks at regular intervals including inspection of system (daily, weekly, quarterly, annually etc.)
  - Plan also involves a checklist for operation, supervision and maintenance.
3. Institutional arrangements and hiring adequate human resource and capacity building.
4. Store Management for availability of tools, parts/spares, equipments, basic materials etc.
5. Maintenance of records and details of materials/tool/equipments purchased like date of purchase, manufacturer details, cost of purchase, warranty, dates for part replacement etc.
6. Financial Arrangements  
It is essential to work out average annual O&M expenditures and work out financial arrangement through user charges, Panchayat/ULBs own funds, other grants etc.

## A3 General Break-Up of O&M Costs

Based on Central Public Health And Environmental Engineering Organisation, following break up of costs for O&M can be adopted:

Type of Expenditure	% of total O & M cost
Human Resource	20-40%
Power/electricity	30-50%
Replacement parts, materials/consumables and miscellaneous	remaining



#### A4 Water Audit and Leakage Control

- Water audit of water supply schemes in simple terms mean estimating loss of water from input to actual distribution to the service area. Water audit can be done through measurements in water and flow meters installed in the water supply system at various points.

#### A5 Energy Audit and Conservation of Energy

- Generally pumping installations consume huge amount of energy wherein proportion of energy cost can be as high as 30-50 percent of overall cost of operation and maintenance of water works. Hence, it is inevitable to estimate and monitor energy consumption on regular basis and takes steps for energy conservation.
- Energy audit in simple term means monitoring energy consumption at various units and sub-units and estimates any wastage of energy due to poor efficiency, higher hydraulic loss or power loss etc.
- Some of the aspects for inefficient use of energy are:
  - ✓ Reduced efficiency of pumps.
  - ✓ Operating point of pump is far than optimum.
  - ✓ Increase in head loss in pumping system due to clogging of strainer, encrustation of column pipes and pumping mains.
  - ✓ Improper/uneconomical diameter of sluice valves, column pipe, drop pipe etc in pumping station.
  - ✓ Wastage of energy due to operation of electrical equipments at low voltage or low power factor.





## MODULE B: OPERATION AND MAINTENANCE OF LOCAL GROUND WATER SOURCES AND MONITORING WATER QUALITY

### Training Objectives

- To understand what steps are needed to be taken for general maintenance of water supply sources for its effective functioning, trouble shooting and its solutions
- To understand sampling and frequency of water quality monitoring from various points in water supply system

**Training tools:** Slideshow, powerpoint/on board presentation, question answer, movies, display of tools etc.

**Approximate time:**

Presentation/slide show: 15 minutes

Slideshow, movies and display of tools: 15 minutes,

Question answer: 15 minutes

TOTAL: 45 minutes

## **B.1 Operation and Maintenance of Dug Well**

Following activities should be carried out for O&M of dug wells within specific time period:

### Monthly/quarterly

- Check for any debris in the well and remove it.
- Clean the concrete apron.
- Check the condition of the rope, pulley, bucket and fence and replace when needed.
- Lubricate the pulley as needed with grease.
- Record the water level with a rope scale.
- Replace the bucket as needed.
- Check the concrete apron and well seal for cracks and repair with cement mortar as needed.
- Verify any structural damage and repair it as per need.

### Yearly:

- Dewater the well and clean the bottom.
- Inspect the well walls and lining and repair as needed.
- Check the water level and deepen/de-silt the well especially in monsoon.
- Check the support posts for the pulley and repair as needed.

## **B.2 Operation and Maintenance of Hand Pump**

### Monthly/quarterly O&M

- Check the hand pump and spout pipe.
- Check all the flange nuts and bolts, axle bolt, flange bolts and tighten as needed.
- Test water quality using a Field Test Kit.
- Tighten the handle axle nut and lock nut.
- Verify whether hand pump is firm on its base and fix it if needed.
- Open the cover and clean inside the pump.
- Check the chain anchor bolt for proper position and tighten if needed.
- Verify rusty patches, clean with a wire brush and apply anticorrosive paint.

### Yearly O&M

- Verify the discharge of water.
- Verify the handle position and repair if needed.
- Verify whether guide bush, roller chain is not excessively worn out and replace if needed.

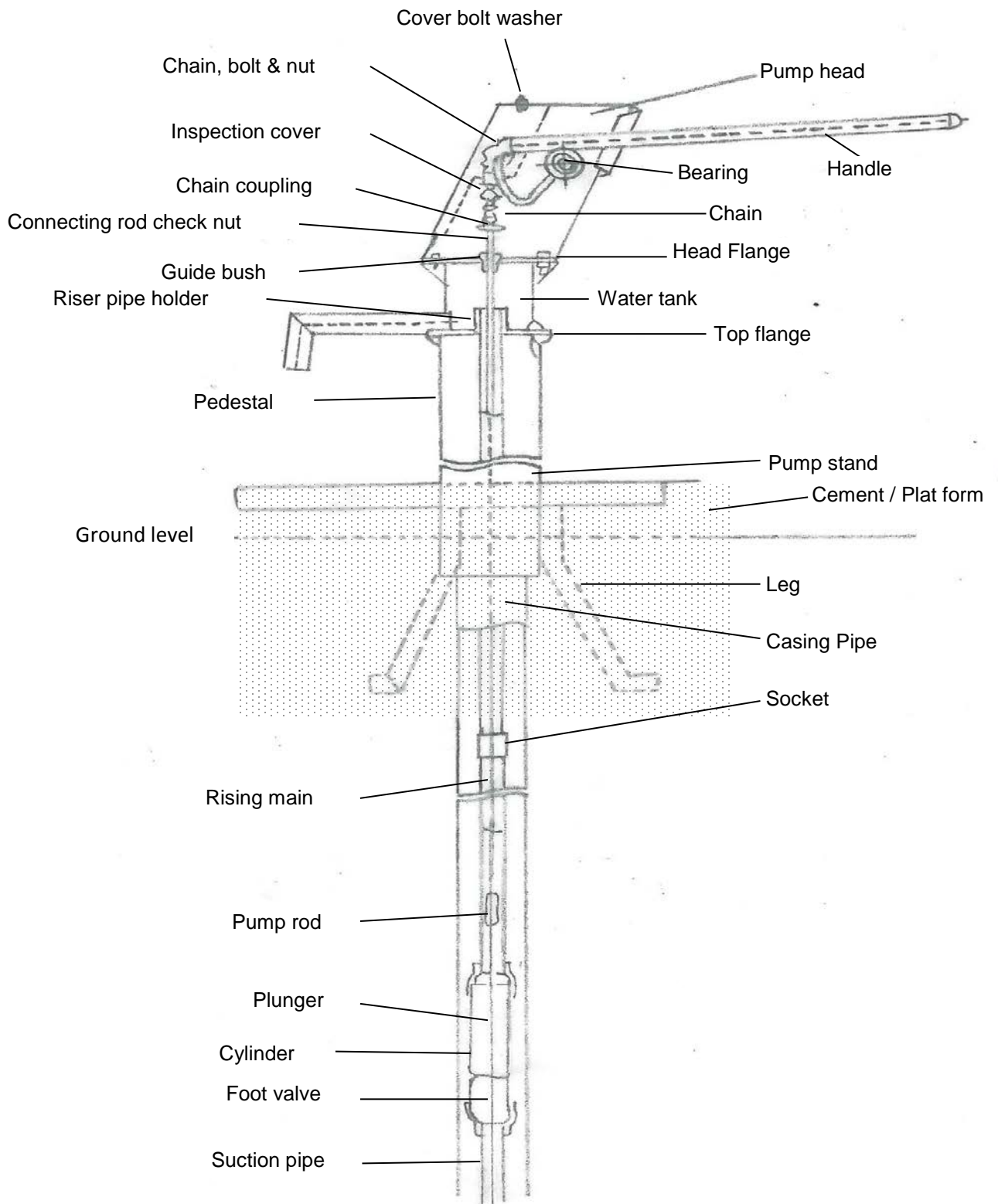

### Trouble Shooting for Hand Pumps

Following are major problems that may occur in use of hand pumps, it is possible causes and suggestive remedies:

Problems	Probable Cause	Suggestive Remedy
Pump Handle works easily, but water is not delivered	No water in the source	Proper development of boring, lowering of cylinder below water level in boring by increasing the riser pipe and pump rod
	Pump has lost its priming	Priming of pump
	Cylinder cup washer are worn out	Replace the cylinder cup washer
	Opening of pump rod joints	Check and tighten the joints
	Breakage of pump rod	Replacement of pump rod
	Hole in suction pipe	Replacement of pipe
	Leakage at base of cylinder	Check and replaces cylinder gasket
	Cracking of pump cylinder	Replacement of cylinder
	Checking/plugging of suction pipe	Dismantle and clear the pipe
Pump is running, but deliver very low amount of water	Plunger leather worn out	Replace the plunger leather
	Refill capacity is not enough	Proper development of boring
	Valve leakage	Repair/ replacement of valves
Need of many strokes for pumping of water	Pump has lost priming	Prime the pump
	Cylinder cup seals worn out	Replace the seal
Pump hand springs up after down stroke	Suction pipe plugged up below cylinder	Remove pump and clean the pipe
	Suction pipe is too small	Replace it with bigger pipe
	Water table is below cylinder assembly	Placement of cylinder near water
Pump is noisy	Pump handle of other working parts are loose	Tighten the parts
	Improper pump rod size	Replace with appropriate pump rod
	Pump rod is loose	Tighten the pump rod
	Top stand of pump stand assembly is not in level	Level the assembly
	Hand pump stand assembly is loose on ground	Check the assembly and grout it properly with cement concrete
	Stand assembly requires lubrication	

Dismantling of hand pump for inspection and repairs

a. Tools for dismantling of hand pump

Self Locking clamp: It is used for pulling and lowering of riser pipe

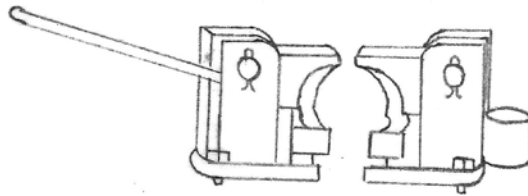

Tool for holding chain coupler: It is used to attach chain with handle. It is used between chain coupler and head assembly flange



Tool for lifting/lowering of pump rod

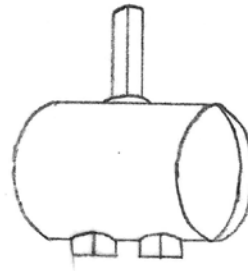

Pump Rod Vice: It is used for holding the pump rod for repairing and thread cutting

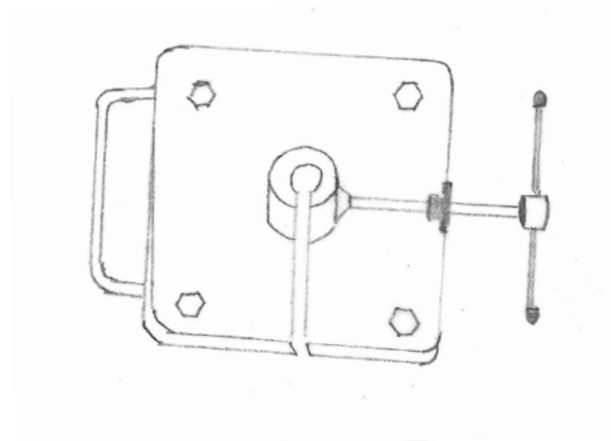

Other tools: Pipe wrench and spanners, hammers, screw drivers etc.

b. Method for dismantling of hand pump

1. Remove inspection cover from head assembly.
2. Fix the tool for holding the chain coupler inside the head assembly.
3. Release the chain with handle after loosening the nut and bolt in upward position of the handle.

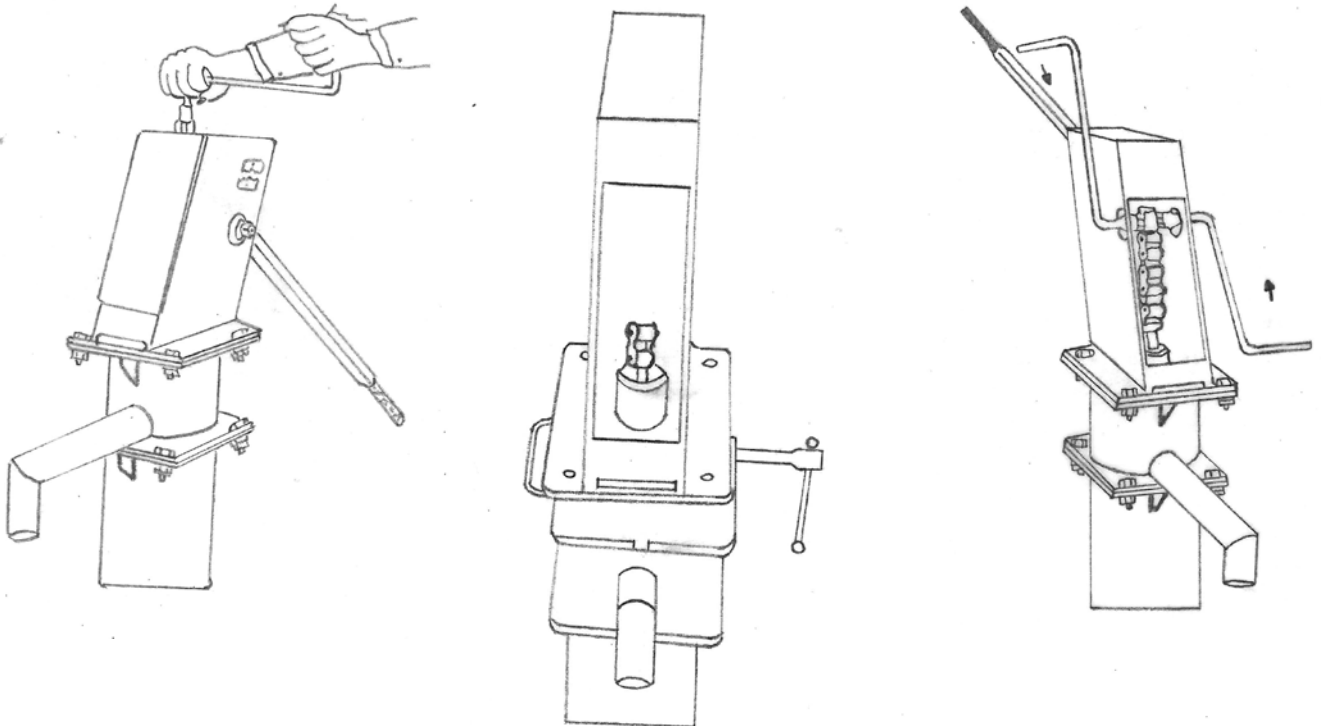

4. Release the handle axle by using punch and hammer. Release the handle and flange bolts from head assembly.
5. Insert the pipe spanners in both side holes of the head assembly and lift the head assembly in upward direction.
6. Fix the pump rod vice in the flange of water tank after lifting of head assembly in upward direction.
7. Rotate the head after loosening the lock nut of head assembly. Remove the chain assembly and head assembly.
8. Remove the pump rod vice after lifting the pump rod in upward direction with the help of lifter. Remove the lifter after lowering the pump rod in upward direction.
9. Hold the riser main pipe by self locking clamp/locking clamp and remove the water tank after loosening of bolts of bottom flange of water tank.
10. Remove the self locking clamp at the time of dismantling of last riser pipe and pump rod.
11. Dismantle the last riser pipe and pump rod from cylinder.

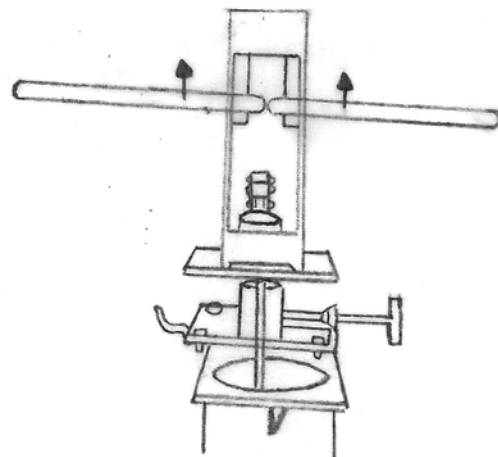
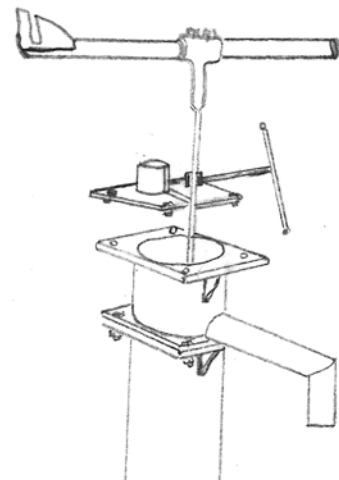

### Re-assembly of hand pump after repairs/cleaning

#### Inspection prior to reassembly

- Check the water tank for leakage/damage.
- Wash and clean all the parts with mixture of kerosene oil and water.
- Check the stand assembly level with spirit level.
- Check the coupler for broken threads.
- Clean the flanges and spout pipe for crack and leakage.
- Check the handle axle, bearings and chain; apply grease to the bearings and chain.

#### Re-assembly of hand pump

- Remove cover of casing pipe for fixing stand assembly.
- Place stand assembly over casing pipe with proper alignment and level.
- Fix water tank assembly on the stand flange by tightening the nuts and bolts.
- Join the check valve and plunger. Connect the plunger to the connecting rod.
- Insert the plunger assembly connected with the check valve in the riser pipe and connect the riser coupler to the water tank.
- Insert the lower end of the connecting rod in the riser pipe, and place the connecting rod over the water tank and fix it to the vice.
- Join the connecting rod pieces as per the requirement and insert in the riser pipe.
- Remove the connecting rod vice from the water tank by holding the top end of the connecting rod.
  - Fix the connecting rod lifter to the top end of the connecting rod and rotate in the direction of the arrow so as to separate the check valve from the plunger and ensure that it reaches the bottom plate.
  - Make a mark by hack saw on the connecting rod at the level of the water tank.
  - Lift the connecting rod assembly, fix the connecting rod vice and tighten the connecting rod.
  - Cut the connecting rod as per the marking after removing the connecting rod lifter.
  - Smoothen with the help of a file the cut surface of the connecting rod.
  - Make necessary threads on the top most end of the connecting rod.
  - Fix the middle flange on the top of the water tank and ensure that all four corners coincide.
  - Tighten the check nut at the top of the connecting rod.
  - Screw the chain on to the connecting rod.
  - Place the chain coupling supporting tool on the middle flange and remove the rod vice.
  - Place the middle flange and set flanges with water tank.
  - Place head assembly over the middle flange and tighten by spanner.
  - Place handle assembly and insert the handle axle by handle axle punch.
  - Lift the handle for fixing chain and tighten chain anchor bolt and nylon nut fully (i.e., nylon insert lock nut); remove chain coupler supporting tool by lowering the handle
  - Lift handle up and apply grease on the chain.
  - Lower down the handle and fix inspection cover and tighten the cover bolt fully by the crank spanner.



### B.3 Operation and Maintenance of Tube/Bore Well

#### Daily O&M:

- Operate pump starter and isolation valve.
- Check reading on ammeter is normal – stop pump if electric motor is drawing too much current.
- Verify whether adequate water is being delivered.
- Continue to check voltmeter and ammeter readings during the day.

#### Monthly/quarterly:

- Clean the pump house.
- Check for leaks in the rising main.
- Testing water quality using a Field Test Kit.

#### Annual O&M:

- Remove the pump and rising main from the well and inspect.
- Check pipe threads and re-cut corroded or damaged threads.
- Replace badly corroded pipes.
- Inspect electric cables and check insulation between cables.
- Record servicing and maintenance in log book.
- De-silt borehole if required.
- Check screen and clear as needed.

#### Trouble shooting of bore/tube wells

Problem	Probable Cause	Remedies
Silting of tube	Over pumping, adverse aquifer conditions, incrustation of screens and aquifers, falling of foreign objects in the bore, damage of mild steel screens due to corrosion	Deepening to appropriate level, repair/replacement of damaged parts, cleaning by chemicals
Decrease in water yield/discharge		
Mechanical Failure		

## B.4 Monitoring Water Quality

In order to ensure potable water for drinking and domestic purpose, it is essential to monitor water quality at regular intervals from source as well as distribution system at regular intervals for estimating type of treatment required for the water. For testing of water, services can be availed from Primary Health Centres in village, Maharashtra Jeevan Pradhikaran (MJP), and health department offices located at block/taluka level, or other water testing laboratories in the region. Certain parameters can be tested through field testing kits locally.

Following chart enlist the frequency and sampling for water quality testing/monitoring. (Source: O&M Manual on water supply systems, CPHEEO)

It is essential that water samples are taken from consumer end (household or stand post etc.) also on regular basis for quality monitoring.

Sampling Frequency for Water Testing from Distribution System		
Population served	Sampling frequency	Minimum number of samples from entire distribution system
Upto 20000	Monthly	1 sample for every 5000 of population per month
20000-50000	Twice a month	
50000-100000	Every four days	

Minimum Sampling Frequency for Water Quality Control Monitoring										
	Size & Source	Frequency	Parameters to be tested							Remarks
			Residual chlorine	Physical	Chemical	Bacteriological	Biological	Heavy metals and pesticides	Other-As, Cr+6, Fe & Mn, flouride	
1	< 50000 population	daily	Y							
	a. Ground water (tube well, open well, etc.)	Quarterly		y	y	y			Y	From source and distribution system
	b. Ground water (hand pump)	Twice a year		y	y	y			Y	In summer and monsoon
2	>50000 upto 100000 population	daily	Y							
	a. Ground water (tube well, open well, etc.)	monthly				Y				From source and distribution system
		Quarterly		y	y				Y	
	b. Ground water	Twice a		y	y	y			y	From source and

	(hand pump)	year								distribution system
		annually						y		

Minimum Sampling Frequency for Water Quality Control Monitoring										
	Size & Source	Frequency	Parameters to be tested							Remarks
			Residual chlorine	Physical	Chemical	Bacteriological	Biological	Heavy metals and pesticides	Other-As, Cr+6, Fe & Mn, flouride	
4	Surface Water a. Raw water, source and intake point	Daily		y	y					
		Weekly				Y				
		Annually						y	Y	
		occasional					y			
	b. sedimentation tank after clarifier	Daily				Turbidity only				
		Weekly				Y				
		Occasional					y			
	c. filtered water	Daily				Turbidity only				
		Weekly				y				
	d. clear water storage reservoir/tanks	Daily	y	y	y					
		Weekly				Y				
	e. distribution system	Daily	Y							
		Weekly				Y				
		monthly		y	y					

## **Activity Sheet**

### **Section B. O&M of local ground water source and water quality monitoring**

1. List various O&M activities for a dug well within specific time period
  
  
  
  
  
  
  
  
  
  
2. List various O&M activities for a hand pump within specific time period
  
  
  
  
  
  
  
  
  
  
3. List various O&M activities for a bore/tube well within specific time period

## MODULE C: OPERATION AND MAINTENANCE OF PUMPING MACHINERY

### Training Objectives

- To understand basics on efficient pump operation and its preventive maintenance
- To understand maintenance of motor, valves and electrical components of pumping machinery

**Training tools:** Slideshow/powerpoint/on board presentation, movies and demonstration, question answer

**Approximate time:**

Presentation: 30 minutes

Slideshow, question answer: 15 minutes

Movies/demonstration: 30 minutes

TOTAL: 1 hour, 15 minutes

Pumping machinery is mainly subjected to wear, tear, erosion and corrosion. Normally, major failure and interruptions in water supply system occur due to problems in pumping machinery. Hence, it is necessary to have timely and effective operation and maintenance of pumping machinery, up keep of pumping stations and records

Record maintenance for O & M of pumping machinery

- Pump operation timings (start and end time daily).
- Voltage in all three phases.
- Current drawn by each pump unit and total units.
- Frequency of operation.
- Readings of vacuum and pressure gauges.
- Bearing temperature for pump and motor.
- Water level in intake/sump.
- Flow meter reading.
- Any specific problem or event in the pumping installation or pumping system.

### **C.1 Basics on Operation of Pumps**

- Avoid dry running of pumps.
- Centrifugal pumps needs to be primed before starting.
- Pumps should be operated only within the recommended range on the head-discharge and characteristics of the pump.
- Increase in distance between duty point and point away reduces the efficiency of pump.
- Operation near shut off causes re-circulation within pump, thus over heating of pump.
- Voltage during operation of pump-motor set should be within + 10 percent of rated voltage.
- Similarly, current should be below the rated current of the motor.
- For water supply schemes, pumps are started against closed delivery valve in order to reduce starting load on motor. Pumps with high specific speed should be started with open delivery valve.
- The delivery valve should be operated gradually to avoid sudden change in flow velocity which can cause water hammer pressures.
- Control the opening of delivery vale during pipeline filling period to avoid overloading on pumps.
- The running of the duty pumps and the standby should be scheduled so that no pump remains idle for long period and all pumps are in ready-to run condition. Similarly,
- If any over vibration or noise is noticed, pump should be stopped immediately.
- Bypass valves of all reflux valve, sluice valve and butterfly valve should be closed during normal operation of the pumps.
- Avoid frequent starting and stopping of pumps for reducing over loading.

## **C.2 Preventive Maintenance of Pumps**

### **Monthly/Quarterly Maintenance**

- Clean the pump, motor and other accessories.
- Check coupling bushes/rubber spider.
- Check stuffing box, gland etc.
- Records of pressure, voltage and current.
- Check and repair of leakage from mechanical seal.
- Check and repair in case of sparks in motor.
- Check for free movement of the gland of the stuffing box.
- Check gland packing and replace if necessary.
- Clean and apply oil to the gland bolts.
- Inspect the mechanical seal for wear and replacement, if necessary.
- Check condition of bearing oil and replace or top up, if necessary.

### **Six Months Maintenance**

- Verify and rectify alignment of pump and drive.
- Clean oil lubricated bearings and replenish with fresh oil.
- Tighten the foundation bolts and holding down bolts of pump and motor mounting on base plate or frame.
- Check vibration level with instruments if available; otherwise by observation.
- Clean flow indicator, other instruments and appurtenances in the pump house.

### **Yearly Maintenance**

- Clean and flush bearings with kerosene and examine for flaws developed like corrosion, wear and scratches.
- Immediately after cleaning, the bearings should be coated with oil or grease to prevent ingress of dirt or moisture.
- Clean bearing housing and examine for flaws like wearing, grooving etc. Change oil or grease in bearing housing.
- Examine shaft sleeves for wear or scour and necessary rectification. If shaft sleeves are not used, shaft at gland packings should be examined for wear.
- Check stuffing box, glands, lantern ring, mechanical seal and rectify if necessary.
- Check clearances in wearing ring.
- Check impeller hubs and vane tips for any pitting or erosion.
- Check interior of volute, casing and diffuser for pitting, erosion, and rough surface.
- All vital instruments i.e. pressure gauge, vacuum gauge, ammeter, voltmeter, watt meters, frequency meter, tachometer, flow meter etc. should be calibrated.
- Conduct performance test of the pump for discharge, head and efficiency.



<b>Common Trouble shooting for Centrifugal Pumps</b>		
Problems	Probable cause	Remedy
Pump motor fails to start	Blown fuse of open circuit breaker	Replace fuse or reset circuit breaker
	Motor of starting switch out of order	Replace and consult supplier/electrician
	Stuffing box tightly packed	Check packing and loosen
	Sand in impeller	Open pump and remove dirt
Water not delivered	Pump has lost its priming	Repeat priming
	Leaks in pipe or suction pipe	Seal the leaks
	No water in the source due to over pumping	Deepening of source
	Collapse of well casing or screens	Replace
	Clogging of well screens	Consult well driller and get it cleaned
Pump is running, but very small amount of water is delivered	Low yield in well	Well deepening
	Air leaks in suction pipe	Pull drop pipe from well and seal the leaks
	Partial clogging of well screens	Consult well driller and get it cleaned
	Impeller is worn out	Clean/replace impellers
	Obstruction of foot valve	Clean foot valve
Noise in pump	Bearing or other part are loose	Tighten or replace parts
	Pump motor is loosely mounted	Tighten the mounting
	Low level of water in well	Reduce pumping rate
	Air in suction pipe	Repair air leaks

<b>Common Trouble shooting for Submersible Pumps</b>		
Problems	Motor overload	Control overload
Pump motor fails to start	Low voltage	
	Fuse blown or loose connections	Replace fuse and rectify connections
	Motor control box not in proper position	Place it in proper position
	Cable, Splice or motor winding may be wet	Verify with ohmmeter and rectify
	Corrosion in pump	Remove corroded parts
Low or no water delivery	Pump not submerged	Lower the unit into well
	Leak in discharge pipe	Repair leaks
	Clogging or cession in check valve	Clean or replace valve
	Pump worn out by abrasion	Replace the pump
	Strainer/ impeller clogged with sand or scale	Clean the parts.
	Corrosion in discharge pipe	Replace it or remove corroded parts
Pressure valve fails to shut	Defects in switch	Adjust or replace pressure switch
	Leaks in discharge pipe	Repair the leaks

### **C.3 Maintenance of Motors**

#### **Monthly/Quarterly Maintenance**

- Clean external surface of motor.
- Examine earth connections and motor leads.
- Check temperature of motor and check whether overheated.
- Lubricate bearings.
- Verify and rectify any abnormal noise in bearings.
- Clean belt tension and reduce it where there is excessive tension.
- Blow dust from the motor.

#### **Six Month Maintenance**

- Clean oil lubricated bearings and replenish fresh oil.
- Wipe brush holders and check contact faces of brushes of slip-ring motors.
- Check insulation resistance of the motor, tightness of cable gland, lug and connecting bolts.
- Check and tighten foundation bolts and bolts holding motor and frame.
- Check vibration level with instrument if available.
- Clean winding of motor, if necessary.

#### **Yearly Maintenance**

- Clean and flush bearings with kerosene and examine for flaws developed, wear and scratches. Cleaned bearings should be coated with oil or grease.
- Change oil or grease in bearing housing.
- Blow out dust from windings of motors thoroughly with clean dry air.
- Clean and varnish dirty and oily windings.
- Check condition of starter, stamping, insulation, terminal box, fan etc.
- Check insulation resistance to earth and between phases of motors windings, control gear and wiring.
- Check air gaps.

### **C.3 Maintenance of Valves**

#### **Foot Valve**

- Clean foot valve once in three months.
- Clean flap of the foot valve once in two months to ensure leak proof operation.
- Inspect the valve thoroughly once in a year. Check for leakage through foot valve after priming.

Sluice valve and Knife gate valve

- Check gland packing once in a month and grease it as per need and change the packing if needed. It should be ensured.
- Apply grease to reduction gears thrust bearing once in three months.
- Check tight closure of the valve once in three months.
- Operate valve once a quarter to full travel.
- Inspect the valve thoroughly for flaws in guide channel, guide lugs, spindle, spindle nut, stuffing box etc. once in a year.

#### Reflux (non-return) valve

- Check proper operation of hinged door and tight closure under no-flow condition once in 3 months.
- The valve shall be thoroughly inspected annually.
- Condition of dampening arrangement should be thoroughly examined once in year and necessary maintenance and rectification should be carried out as per manufacturer's instruction.
- In case of dampening arrangement, check for oil leakage and replace oil once in a year.

#### Butterfly valve

- Check seal ring and tight shut-off once in three months.
- Lubricate gearing arrangement and bearing once in three months.
- Inspect the valve thoroughly including complete operations once in a year.
- Change oil or grease in gearing arrangement once in a year.

### **C.4 Maintenance of Electrical Components (Starters, Breakers, Panel etc.)**

- Clean the external surface and check for spark or leakage current and overheating on daily basis.
- Clean internal components and blow dust, and tighten all connections monthly.
- Check all the connections as per circuit diagram , condition of oil in oil tank and its replacement if needed, check condition of resistance and insulators once in three months.
- Servicing of all components; cleaning and reassembly and calibration of voltmeter, ammeter, frequency meter on annual basis.

**Activity Sheet**

**Section C. O&M of Pumping Machinery**

1. List various points that are recorded on regular basis for operation of pumping machinery
  
  
  
  
  
  
  
  
  
  
  
  
  
  
2. List points for preventive maintenance of pumps
  
  
  
  
  
  
  
  
  
  
  
  
  
  
3. List points for maintenance of motors

## MODULE D: OPERATION AND MAINTENANCE OF WATER TREATMENT UNITS

### Training Objectives

To understand basic operation and maintenance of basic water treatment units

**Training tools:** Slideshow, powerpoint/on board presentation, question answer, Movies

**Approximate time:**

Presentation: 15 minutes

Slideshow, movies: 15 minutes

Question answer: 15 minutes

TOTAL: 45 minutes

## D.1 O&M of slow sand filter

### Daily

- Check the rate of filtration on the flow indicator – adjust the rate of filtration as needed by turning the filtered water valve.
- Check the water level in the filter – adjust the inlet valve as needed to maintain a constant water level.
- Check the water level in the clear well.

### Cleaning of filter - quarterly

- Close the water inlet and allow the filter to discharge clear water for at least 8-10 hours.
- Close the treated water outlet valve.
- Open the waste water outlet till the water in the filter bed reaches upto 0.1-0.2 mm from bottom.
- Remove wastage on top of the filter. Remove the sand as little as possible, not more than 20-30 mm. Wastage can be removed manually or with mechanical equipment. Care should be taken avoid any contamination while removal of waste in the filter tank by observing hygiene and cleaning it as quickly as possible.
- Level the sand in the filter.
- Re-start the filter by opening inlet valves and outlet valves.

After sand cleaning is done for 20-30 times, the depth of sand layer will decrease and needs to be replaced.

## D.2 O&M of Chlorinators

### **Gas Chlorinator**

- Normally O&M instructions are provided by the manufacturer, which should be followed.
- Method for checking chlorine leakage.
  - ✓ Turn on water supply to the ejector.
  - ✓ Open the chlorine cylinder valve not more than ½ turn then close immediately. Check for leaks. A smell of chlorine gas indicates a leak in the set-up. To confirm, dip a cotton or piece of cloth in ammonia solution and expose it near the leakage. Ammonia vapour reacts with chlorine gas to form white fumes.
  - ✓ If leak is confirmed, allow the chlorine gas to dissipate from the air before undertaking any repair.
  - ✓ After the repair, re-check any leakage.
  - ✓ Set the feed rate at the computed or desired chlorine dose level.
- Routine Maintenance
  - ✓ Strainer: Clean the strainer in the ejector water supply line every six months.
  - ✓ O-Rings: O-rings showing brittleness should be replaced.
  - ✓ Vacuum Regulator Valve and Ejector: Clean the vacuum regulator and ejector throat and nozzle at least once a year.
  - ✓ Hose Lines. Inspect all hose lines at least weekly for cracks or weak spots that develop with aging. Faulty lines should be replaced. Use only hoses supplied by the manufacturers of chlorine equipment.

### **Differential Pressure Chlorinator**

- Rubber bag needs to be replaced atleast once a year. The most frequently expected problem is development of holes in the rubber bag. Hence, regular monitoring of the bag should be done.
- The inlet and outlet pipe joints, control valves, drain valves and air release cock are to be maintained watertight.
- The MS container shall also be painted at least once in two years. The container must be cleaned at least fortnightly so that there are no encrustations on container walls and logging of pipes.
- The diaphragm and rubber washers should be replaced periodically, the rubber washer should be replaced when needed.

### **Drip Chlorinator**

- Dropper tube must be verified regularly (daily/weekly) for any blockages/ precipitates. These tubes must be cleaned (monthly if possible) to prevent blockages.
- The main tank body should be cleaned (once in three months). The tanks should be inspected for any cracks/damages regularly and repaired.

## MODULE E: OPERATION AND MAINTENANCE OF WATER DISTRIBUTION SYSTEM AND STORAGE

### Training Objectives

- To understand basics on O&M of storage units in piped water supply
- To understand basics O&M of water meters
- To understand basics on repairs and O&M of pipelines

**Training tools:** Slideshow, powerpoint/on board presentation, movies/ demonstration, question answer

#### Approximate time:

Presentation: 30 minutes

Movies/demonstration: 30 minutes

Question answer: 15 minutes

TOTAL: 1 hour, 15 minutes



### E.1 O&M of Sump and Storage Tanks

- Remove all foreign floating materials quarterly.
- Care should be taken to dump the removed silt away from pump house.
- Dewater and tank once a year, clean it and disinfect it. For cleaning, brush the walls, column, ladders, and other parts of the tank to remove dirt and algae, if any. For disinfecting the tank, fill the tank with 50 mg/litre chlorine solutions and allow the solution to stand for 24 hours before draining it to waste. Rinse the tank with clean water once and then use the tank again.
- Undertake leakage test once a year and carry out rectification if needed with epoxy coating, cement concreting, painting etc.

### E.2 O&M of Water Meters

Regular maintenance of water meters include cleaning of dirt box or strainer time to time, replacement of gaskets upon its wear and tear, cleaning of chamber where meter is installed and prevent water seepage in it, verifying whether it is indicating correct reading cleaning of spare parts when disassembled for any repairs or verification with detergents solution in warm water.

Normally, general maintenance and repairs recommendations are given by the manufacturer.

Trouble shooting of water meters

Problem	Probable Cause	Solution
Meter reads in reverse direction	Meter is installed in reverse direction	Re-install it
No recordings in meter	Impeller to register link broken	Undertake service/repairs
Pointer moves but no change in indicator	Pointer and drum link missing, drum defect	Undertake service and repairs
Meter runs slow or fast	Inlet flow disturbance, magnets might have worn out	Clean the external filter/dirt box. Undertake servicing
Leakage in bush/gland	Deformity in gland	Undertake service/repair
Regulator, head/body leakage	Washer is damaged. Screws are loose	Service/repair

### E.2 O&M of Flow Meters

Regular monitoring of flow meters include periodic checking of range and zero setting, bearing wear out checking, deposits in flow meter, corrosion of attached pipes etc. Some of the general trouble shooting is listed below:

Probable Cause	Solution
<b>Problem: Erratic Reading</b>	
Operating below lower ranges	Replacement of meter, change range setting
Lower static pressure	Remove air trap
Clogged impulse piping	Clear choke up
Air trap in impulse piping	Remove air trap
Frequent air trap in impulse piping	Change piping slope/change meter
<b>Problem: Inaccurate Reading</b>	
Pipeline internally incrustated	Clean internal surface of pipeline
Scaling at tapping points	Clean the tapping points
Orifice edge blunt	Replace orifice plate
Mismatch of flow meter and pipeline	Remove the mismatch
Gathering of concrete piece, bricks, debris etc at orifice	Remove the external particles

Leakage in flanged coupling	Rectify the leakage
-----------------------------	---------------------

### E.3 Repairs, Operation and Maintenance of Pipelines

#### Issues in transmission main

- Leakage of water through leaking pipes, joints, valves and fittings due to poor material, poor craftsmanship or due to weathering, corrosion and aging of system.
- Leakage of water through appurtenances: Leakages of water through glands of sluice valves, loosening of bolts due to expansion joints, damages in gaskets etc.
- Air Entrainment: Accumulation of air in the system leading to decreased efficiency of system and pump, bursting of pipes, malfunctions of valves etc.
- Water Hammer: Water hammer occurs due to rapid closure of valves or sudden shut off or failure of power supply to the pumps. This results in damages to valves in the pipeline or bursting of pipes in certain cases.



#### Sound Operation for water supply lines

- Always maintain positive line pressure. Negative pressure could result in backflow from storage and the intrusion of foreign water/matter that will contaminate the system.
- Always open and shut off valves gradually. Sudden opening or closing will lead to surges, changes in water velocity, low reversal, water hammer, make water dirty and damage valves as well as pipe joints.
- Regularly flush the system to clear sediments from the system.

#### Finding leakages in water mains

- a. Visual observation
  - This method is the simplest and most applicable leak detection technique for use in small water supply systems. This requires being alert to the following signs of leaks:
    - ✓ Appearance of wet spots during dry season.
    - ✓ Greening of patches of ground in areas where plants normally do not grow.
    - ✓ Abnormal drops in pressure.
- b. Finding exact position of leaks with sounding rod
  - After finding the approximate location of leaks in the water distribution system, their exact location can be determined by using a sounding rod. Leaks in water pipes usually make sound, small leaks make more noise than large ones. The sounding rod is a pointed metal rod used to relay to the observer the sound caused by leaks in buried pipes. The procedure involves the following:
    - ✓ Push the sounding rod into the ground until its end touches the buried pipe, without damaging the pipe.

- ✓ Put ear to the exposed end of the rod and listen for the sound. If the sound is too faint, a hearing aid such as a stethoscope will be helpful.
- ✓ The region where sound is fainter than other areas is the region where probable leaks would be found.
- ✓

#### Verification and general maintenance of piping system

- Regular verification (monthly/weekly) for leaks in pipelines (physical or mechanical pipe locator), pipe joints and valves and replacement of parts like gaskets, valves, joints where necessary.
- Regular flushing, cleaning and disinfecting the mains usually that carry raw water. Flushing can be carried out annually.
- Servicing of valves to prevent corrosion and its replacement when needed.
- Verification of valve chambers for appropriate covers and water logging.
- Repairs of pipelines, where damaged.
- Flushing of pipelines (carrying raw water) at regular interval is required to remove impurities and suspended particles. Mechanical devices are also used like swabs and pigs if flushing does not improve water quality. Scrapers or brushes are used in pipelines with hardened scales or extensive tuberculation.
- Cement mortar lining for certain metal pipelines should be taken up with passage of time and corrosion is visible to prevent water contamination. Such lining can be taken up when pipe carrying capacity has reduced, water quality is affected due to corrosion and there are leaks in joints and pipe walls.

#### Flushing of pipeline

- Isolate the water mains to be cleaned by closing the appropriate control valves.
- Empty the water mains by opening the valve.
- Inject water at high-induced velocity (1 m per second or higher) until the waste materials are expelled.
- As needed, disinfect the pipelines. After disinfection, flush the pipeline with clean water until the chlorine-odour is not detectable.
- Put pipelines back to operation.

#### Repairs of pipes

- Excavate the areas where pipe has to be repaired. Before any repairs, close the water supply for the areas that has to be repaired by closing the valves and let it dry completely. Once repaired, disinfect the repaired section. Open the water supply/valve and check for leakage in repaired area. Back fill the trench once the testing is done.
- Repairing PVC pipes  
Cut the part where pipes are damaged and deburr the ends. Fix new pipe/fittings with cement solution into coupler and wait for at least 15 minutes before water supply.

For small holes in pipeline, many times hot air welding/ plastic welding is also used to repair holes.

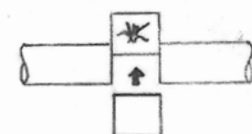
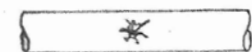

- Repairing HDPE pipes  
For temporary and small damage (scratches, very small hole etc.), full circle clamps are used for repairing of HDPE pipes.

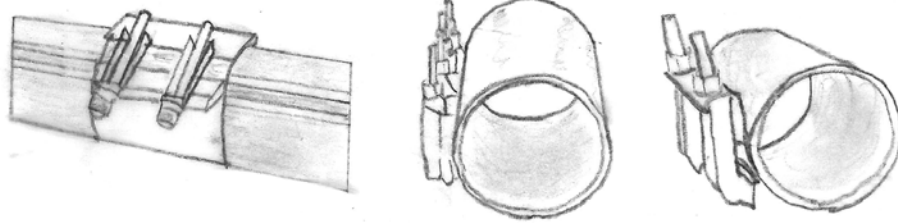

Mechanical pipe fitting are used where the pipes have cracks or deep scratches and big puncture. The water supply is closed and part of pipe which is damaged is cut and mechanical coupling as per the required diameters is installed.

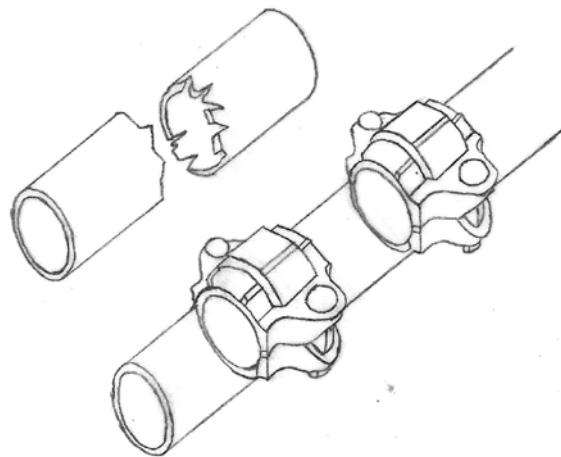
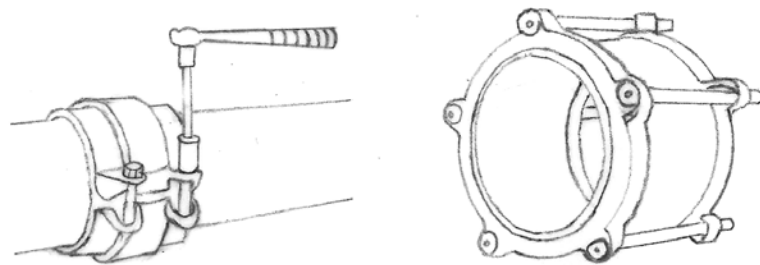

- Repairing metal Pipes

- a. Clamps for small damages like scratches, small holes etc.

- ✓ Loosen all the nuts on the clamp.
- ✓ Slide the washer plate to the nuts and open clamp.
- ✓ Lubricate the rubber mat with approved pipe lubricant.
- ✓ Position the clamp over the damaged area in the pipeline.
- ✓ Wrap the clamp around the pipe and lock into position with the washer plate.
- ✓ Spin the nuts down making sure the clamp has not moved from the desired position on the damaged pipe.
- ✓ Tighten the nuts.

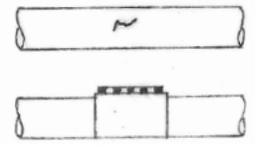

- b. Couplings for damages like crack, pits etc.

- ✓ Cut the damaged area of pipe.
- ✓ Open the nuts of the coupling and place the coupling on the pipes to be joined with rubber gasket.
- ✓ Close the coupling and tighten the nuts.

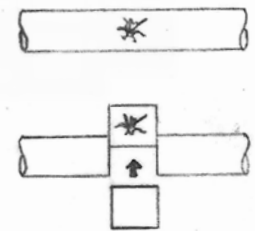

- c. Metal Pipes can also be repaired by welding.

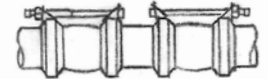



## References

- Ministry of Rural Development, Department of Drinking Water Supply, Government of India, Water and Sanitation Program; **A Handbook for Gram Panchayats -To Help Them Plan, Implement, Operate, Maintain and Manage Drinking Water Security.**
- François Brikké and Maarten Bredero, World Health Organisation and IRC Water and Sanitation Centre, Geneva, Switzerland; Linking technology choice with operation and maintenance in the context of community water supply and sanitation, A reference document for planners and staff, 2003.
- Ministry of Rural Development, Department of Drinking Water Supply, Government of India, Rajiv Gandhi National Drinking Water Mission, Implementation Manual on National rural drinking water quality monitoring and surveillance programme.
- Water and Sanitation Management Organisation, Government of Gujarat, Repair & Maintenance Guidelines for Pani Samiti (Gujarati).
- Jan 2005, Manual on Water Supply & Treatment, CPHEEO, Ministry of Urban Development, New Delhi.
- Feb 2012, "Operation and Maintenance Manual"- Rural Water Supply, Volume -3, Water Partnership Program, World Bank, Manila, Philippines.

Source for photographs on cover page:

- [www.edgeoutreach.com](http://www.edgeoutreach.com)
- [www.ptdqc.com](http://www.ptdqc.com)

## The Performance Assessment System (PAS) Project

The Performance Assessment System (PAS) Project aims to develop appropriate methods and tools to measure, monitor and improve delivery of water and sanitation in cities and towns in India. The PAS Project includes three major components of performance measurement, performance monitoring and performance improvement. It covers all the 400+ urban local governments in Gujarat and Maharashtra.

CEPT University has received a grant from the Bill and Melinda Gates Foundation for the PAS Project. It is being implemented by CEPT University with support of Urban Management Centre (UMC) in Gujarat and All India Institute of Local Self-Government (AIILSG) in Maharashtra.

### PAS Project

CEPT University

Kasturbhai Lalbhai Campus, University Road, Navrangpura, Ahmedabad 380 009 Gujarat, India

Tel: +91-79-26302470

Fax: +91-79-26302075

[www.pas.org.in](http://www.pas.org.in)